

Born For Rental

MOBILE POWER SOLUTION

Designed To Meet Varsity Of Needs
Mobile Power Solution Featured With

- Mobile Solar Surveillance
- Mobile Solar LED Lighting
- Mobile Solar Generator
- Mobile Solar Telecom

BIGLUX INNOVATION LTD



Mobile Solar CCTV Solution

Rental · Resale · Ownership · Distribution
One-Time Investment · Long-Term Returns



OUR SERVICE

Reliable Support For Your Mobile Solar Solutions

BiGLUX centers on solar monitoring & lighting trailer tower services and tailored solutions, we supply full-cycle support from analysis, design, manufacturing to maintenance for our customers.



24-Hour
Quick Response



3-Step
Quality Control



7-Day
Fast Delivery



2-Year
Solid Warranty

HiSOLO™

MOBILE SOLAR CCTV TOWER

Rental. Sale. Own. Lease

- No Electricity
- No Network
- No Fuel
- No Problem!



CCTV BOX

- Six-Sided Structure
- 360° Rotatable
- Cooling Fan Inside
- Faster On-Site Deployment
- Easy Installation & Maintenance
- Removable Mounting Plate
- Rear-Opened
- 4 Strobe Lights

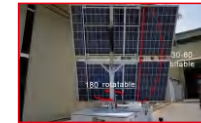

SOLAR PANELS

- 180° Full Rotation
- Up to 1200W Power Rating
- Flexible Adjustment
- Maximized Sun Exposure
- Time-Saving Deployment
- 30-60° Electric Tilt
- Rear-Opened

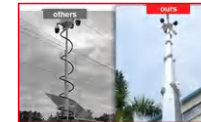

BUILT-IN WIRES

- Internal Wiring
- Each Section Hot-Dip Galvanized
- Weatherproof Aging Prevention
- Against Cutting or Vandalism
- Extended Service Life
- Up to 9 Meters Height

PRODUCT SKETCH

TECHNICAL DATA

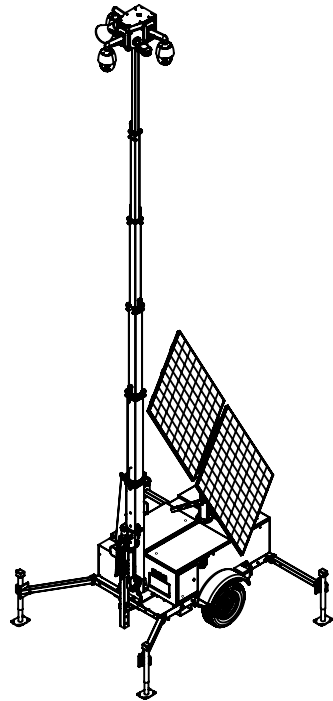

BASIC VERSION	BL2P-G7MHSS0B	BL2P-L7MHSS0B
Solar		
Solar Panel	2x450W, Bifacial	
Panel Rotating	180° Manual	
Panel Tilting	30°-60° Electrical	
MPPT Controller	50A-E With Remote Battery Monitoring	
Estimated Solar Charging Time	9 hours	
Battery		
Battery Type	GEL	LFP
Battery Capacity	9600WH	8038WH
Battery AC Charger	1.5kW, AC110V/230V	
System Voltage	DC 24V	
Available Voltage	DC 24V, 48V	
DC-to-AC Inverter	450W Rated	
Battery Backup Time	72 Hours Under 90W Load	
Telescopic Mast		
Mast Height	6.5M	
Lifting Winch	Manual	
Material	Hot-dip Galvanized Steel	
Feature	Build in Wiring	
CCTV		
CCTV BOX	350° Rotatable, 6-sided, back-opened	
Strobe Light	Blue&White	
Included Accessories	8-Port POE Switch	
Optional Accessories	Cameras, NVR, 4G Router, Loud Speaker	
General		
Working Temp	-20°C~55°C	
Extended Dimensions	3522*3246*7232mm	
Retracted Dimensions	3522*1630*2880mm	
Gross Weight	1000KG	
QTY in 20' / 40'	6 units / 14 units	

PRO VERSION	BL2P-G9EHSS0P	BL2P-L9EHSS0P
Solar		
Solar Panel	2x600W, Bifacial	
Panel Rotating	180° Manual	
Panel Tilting	30°-60° Electrical	
MPPT Controller	45A-V With Remote Battery Monitoring	
Estimated Solar Charging Time	10 hours	
Battery		
Battery Type	GEL	LFP
Battery Capacity	12000WH	14336WH
Battery AC Charger	1.5kW, AC110V/230V	
System Voltage	DC 24V	
Available Voltage	DC 24V, 48V	
DC-to-AC Inverter	450W Rated	
Battery Backup Time	72 Hours Under 133W Load	
Telescopic Mast		
Mast Height	8.5M	
Lifting Winch	Electrical	
Material	Hot-dip Galvanized Steel	
Feature	Build in Wiring	
CCTV		
CCTV BOX	350° Rotatable, 6-sided, back-opened	
Strobe Light	Blue&White	
Included Accessories	8-Port POE Switch	
Optional Accessories	Cameras, NVR, 4G Router, Loud Speaker	
General		
Working Temp	-20°C~55°C	
Extended Dimensions	4037*3246*9350mm	
Retracted Dimensions	4037*1630*3100mm	
Gross Weight	1100KG	
QTY in 20' / 40'	6 units / 14 units	

HiSKID-II™

MOBILE SOLAR CCTV TOWER

Rental. Sale. Own. Lease

- No Electricity
- No Network
- No Fuel
- No Problem!



CCTV BOX

- Six-Sided Structure
- 360° Rotatable
- Cooling Fan Inside
- Faster On-Site Deployment
- Easy Installation & Maintenance
- Removable Mounting Plate
- Rear-Opened
- 4 Strobe Lights



SOLAR PANELS

- 180° Full Rotation
- Up to 1200W Power Rating
- Flexible Adjustment
- Maximized Sun Exposure
- Time-Saving Deployment
- 30-60° Electric Tilt



FORKLIFT BASE

- Large fork holes
- 4 reinforced lifting rings
- Fork/lift for easy movement
- Flexible adjustment suits varied terrains
- 4 adjustable jacks

PRODUCT SKETCH

TECHNICAL DATA

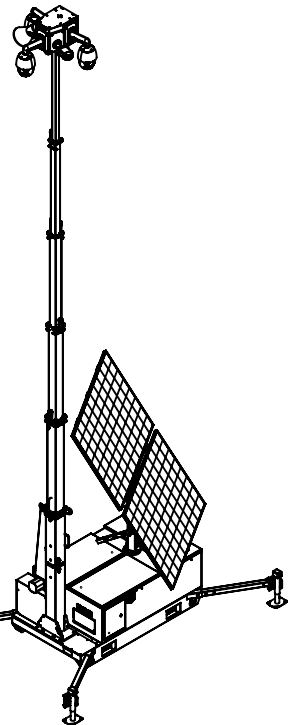

BASIC VERSION	BL2P-G7MHDS0B	BL2P-L7MHDS0B
Solar		
Solar Panel	2x450W, Bifacial	
Panel Rotating	180° Manual	
Panel Tilting	30°-60° Electrical	
MPPT Controller	50A-E with remote battery monitoring	
Estimated Solar Charging Time	9 hours	
Battery		
Battery Type	GEL	LFP
Battery Capacity	9600WH	8038WH
Battery AC Charger	1.5kW, AC110V/230V	
System Voltage	DC 24V	
Available Voltage	DC 24V, 48V	
DC-to-AC Inverter	450W Rated	
Battery Backup Time	72 Hours Under 90W Load	
Telescopic Mast		
Mast Height	6.5M	
Lifting Winch	Manual	
Material	Hot-dip Galvanized Steel	
Feature	Build in Wiring	
CCTV		
CCTV BOX	350° Rotatable, 6-sided, back-opened	
Strobe Light	Blue&White	
Included Accessories	8-Port POE Switch	
Optional Accessories	Cameras, NVR, 4G Router, Loud Speaker	
General		
Working Temp	-20°C~55°C	
Extended Dimensions	3522*3246*7232mm	
Retracted Dimensions	3522*1630*2880mm	
Gross Weight	1000KG	
QTY in 20' / 40'	6 units / 14 units	

PRO VERSION	BL2P-G9EHDS0P	BL2P-L9EHDS0P
Solar		
Solar Panel	2x600W, Bifacial	
Panel Rotating	180° Manual	
Panel Tilting	30°-60° Electrical	
MPPT Controller	45A-V With Remote Battery Monitoring	
Estimated Solar Charging Time	10 hours	
Battery		
Battery Type	GEL	LFP
Battery Capacity	12000WH	14336WH
Battery AC Charger	1.5kW, AC110V/230V	
System Voltage	DC 24V	
Available Voltage	DC 24V, 48V	
DC-to-AC Inverter	450W Rated	
Battery Backup Time	72 Hours Under 133W Load	
Telescopic Mast		
Mast Height	8.5M	
Lifting Winch	Electrical	
Material	Hot-dip Galvanized Steel	
Feature	Build in Wiring	
CCTV		
CCTV BOX	350° Rotatable, 6-sided, back-opened	
Strobe Light	Blue&White	
Included Accessories	8-Port POE Switch	
Optional Accessories	Cameras, NVR, 4G Router, Loud Speaker	
General		
Working Temp	-20°C~55°C	
Extended Dimensions	4037*3246*9350mm	
Retracted Dimensions	4037*1630*3100mm	
Gross Weight	1100KG	
QTY in 20' / 40'	6 units / 14 units	

HiGUARD™

MOBILE SOLAR CCTV TOWER

Rental. Sale. Own. Lease

- No Electricity
- No Network
- No Fuel
- No Problem!

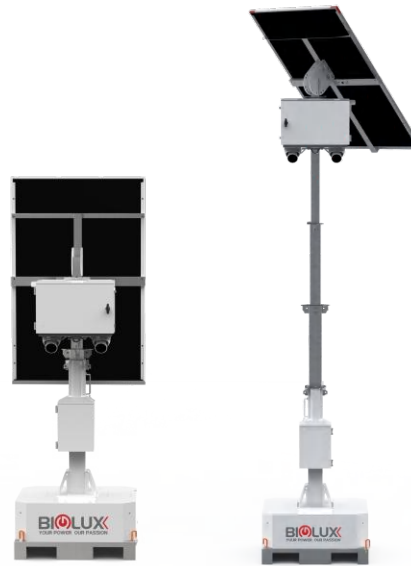

DURABLE BASE

Hot-dip galvanized forklift base
Scratch and corrosion resistant
Heavy-duty hooks for easy hoisting
Fillable for enhanced stability



CAMERA MOUNTING PLATE

Front/Rear/Bottom Mounts
Quick Installation
DC 24V/48V Output

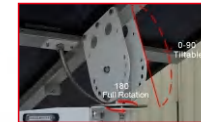

FLEXIBLE ADJUSTMENT

180° Rotation & 90° Tilt
Flexible Deployment
Maximum Sunshine Exposure

PRODUCT SKETCH

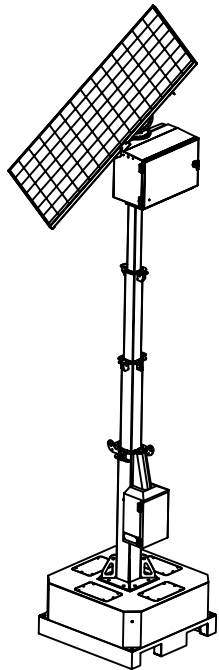

TECHNICAL DATA

BASIC VERSION	BL1P-L4MHGS0B
Solar	
Solar Panel	1*450W Bifacial
Panel Adjustment	90°tiltable, 180°rotatable
MPPT Controller	20A-E
Battery	
Battery Type	LFP
Battery Capacity	2560Wh
AC Charger	NO
CCTV	
Available Voltage	24V/48V
Estimated Charging Time	4.8 hours
Running Time	72 hours on 28W
8-Port POE	NO
Optional Accessories	POE, 4G Router, NVR, Cameras
Structure	
Mast & Height	3.5M, Hot-Dip Galvanized
Mast Lifting	Manual Winch
Base	Hollow, Metal, Hot-Dip Galvanized
Lifting Ring	4 ×
Forklift Holes	2 ×
General	
Extended Dimensions	1134*1100*5221.5mm
Retracted Dimensions	1134*1100*3157.5mm
Weight	360KG
QTY in 20' / 40' Container	12 units / 28 units

PRO VERSION	BL1P-L4MHGS0P
Solar	
Solar Panel	1*450W Bifacial
Panel Adjustment	90°tiltable, 180°rotatable
MPPT Controller	35A-V (with remote battery monitoring)
Battery	
Battery Type	LFP
Battery Capacity	4019WH
AC Charger	YES
CCTV	
Available Voltage	24V/48V
Estimated Charging Time	6 hours
Running Time	72 hours on 44W
8-Port POE	YES
Optional Accessories	Router, NVR, Cameras
Structure	
Mast & Height	3.5M, Hot-Dip Galvanized
Mast Lifting	Manual Winch
Base	Hollow, Metal, Hot-Dip Galvanized
Lifting Ring	4 ×
Forklift Holes	2 ×
General	
Extended Dimensions	1134*1100*5321.5mm
Retracted Dimensions	1134*1100*3257.5mm
Weight	470KG
QTY in 20' / 40' Container	12 units / 24 units

HiSITE™

MOBILE SOLAR CCTV TOWER

Rental. Sale. Own. Lease

- No Electricity
- No Network
- No Fuel
- No Problem!



CCTV BOX

- Six-Sided Structure
- 360° Rotatable
- Cooling Fan Inside
- Faster On-Site Deployment
- Easy Installation & Maintenance
- Removable Mounting Plate
- Rear-Opened
- 4 Strobe Lights



RUST RESISTANCE

- Hot-dip galvanized telescopic mast base and outriggers
- Zinc coating average thickness $\geq 100\mu\text{m}$
- Outdoor powder-coated shell
- Rust-proof in long-term humid environments

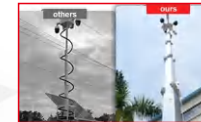

BUILT-IN WIRES

- Internal Wiring
- Each Sections Hot-Dip Galvanized
- Weatherproof Aging Prevention
- Against Cutting or Vandalism
- Extended Service Life

PRODUCT SKETCH

TECHNICAL DATA

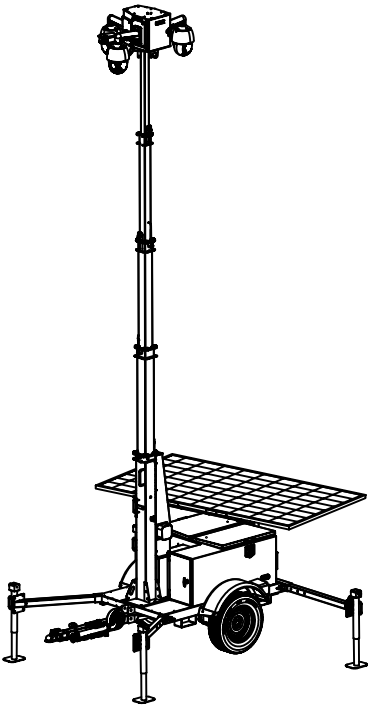

BASIC VERSION	BL1P-G7MHS0B
Solar	
Solar Panel	1×720W, Bifacial
Panel Rotating	0°-60° Manual
Panel Tilting	30°-60° Manual
MPPT Controller	30A-E
Estimated Solar Charging Time	7 hours
Battery	
Battery Type	GEL
Battery Capacity	6000WH
Battery AC Charger	1.5kW, AC110V/230V
System Voltage	DC24V
Available Voltage	DC 24V,48V
DC-to-AC Inverter	NO
Battery Backup Time	72 Hours Under 66W Load
Telescopic Mast	
Mast Height	6.5M
Lifting Winch	Manual
Material	Hot-dip Galvanized Steel
Feature	Build in Wiring
CCTV	
CCTV BOX	350° Rotatable, 6-sided, back-opened
Strobe Light	Blue&White
Optional accessories	Cameras, NVR, 4G Router, Loud Speaker
General	
Working Temp	-20°C~55°C
Extended Dimensions	2384*1800*7000mm
Retracted Dimensions	2384*1800*3000mm
Gross Weight	900KG
QTY in 20' / 40'	8 units / 16 units

PRO VERSION	BL1P-L7MHS0B
Solar	
Solar Panel	1×720W, Bifacial
Panel Rotating	0°-60° Manual
Panel Tilting	30°-60° Manual
MPPT Controller	30A-E
Estimated Solar Charging Time	8.4 hours
Battery	
Battery Type	LFP
Battery Capacity	7168WH
Battery AC Charger	1.5kW, AC110V/230V
System Voltage	DC24V
Available Voltage	DC 24V,48V
DC-to-AC Inverter	NO
Battery Backup Time	72 Hours Under 80W Load
Telescopic Mast	
Mast Height	6.5M
Lifting Winch	Manual
Material	Hot-dip Galvanized Steel
Feature	Build in Wiring
CCTV	
CCTV BOX	350° Rotatable, 6-sided, back-opened
Strobe Light	Blue&White
Optional accessories	Cameras, NVR, 4G Router, Loud Speaker
General	
Working Temp	-20°C~55°C
Extended Dimensions	2384*1800*7000mm
Retracted Dimensions	2384*1800*3000mm
Gross Weight	850KG
QTY in 20' / 40'	8 units / 16 units

HiCUBE™

MOBILE SOLAR CCTV TOWER

Rental. Sale. Own. Lease

- No Electricity
- No Network
- No Fuel
- No Problem!



HIGH-POWER SOLAR PANELS

Feature 1: High-Power Solar Panels
 3×450W bifacial panels for higher efficiency
 Triple-panel foldable design for easy deployment
 Same-direction panels to boost power generation
 Electric angle adjustment for different latitudes



LOWER SHIPPING COSTS

Up to 18 units fit in one 40HQ container
 Maximize capacity in limited space
 Directly cuts average shipping cost
 Achieves cost-saving on logistics



RUST RESISTANCE

Hot-dip galvanized telescopic mast base and outriggers
 Zinc coating average thickness ≥100µm
 Outdoor powder-coated shell
 Rust-proof in long-term humid environments

PRODUCT SKETCH

TECHNICAL DATA

BASIC VERSION	BL3P-L7EHC50B
Solar	
Solar Panel	3×450W, Bifacial
Panel Tilting	0°-60° Electrical
MPPT Controller	30A-E with remote battery monitoring
Estimated Solar Charging Time	9 hours
Battery	
Battery Type	LFP
Battery Capacity	10240WH
Battery AC Charger	2.5kW AC110V/230V
System Voltage	DC 48V
Available Voltage	DC 24V,48V
DC-to-AC Inverter	450W Rated
Battery Backup Time	72 Hours Under 114W Load
Telescopic Mast	
Mast Height	6.5M
Lifting Winch	Electrical
Material	Hot-dip Galvanized Steel
Feature	Build in Wiring
CCTV	
CCTV BOX	350° Rotatable, 6-sided, back-opened
Strobe Light	Blue&White
Included Accessories	8-Port POE Switch
Optional Accessories	Cameras, NVR, 4G Router, Loud Speaker
General	
Working Temp	-20°C~55°C
Extended Dimensions	3225*3600*6962mm
Retracted Dimensions	1315*1385*2840mm
Gross Weight	945KG
QTY in 20' / 40'	8 units / 18 units

PRO VERSION	BL3P-L7EHC50P
Solar	
Solar Panel	3×450W, Bifacial
Panel Tilting	0°-60° Electrical
MPPT Controller	35A-V with remote battery monitoring
Estimated Solar Charging Time	9.6 hours
Battery	
Battery Type	LFP
Battery Capacity	15360WH
Battery AC Charger	2.5kW AC110V/230V
System Voltage	DC 48V
Available Voltage	DC 24V,48V
DC-to-AC Inverter	450W Rated
Battery Backup Time	72 Hours Under 170W Load
Telescopic Mast	
Mast Height	6.5M
Lifting Winch	Electrical
Material	Hot-dip Galvanized Steel
Feature	Build in Wiring
CCTV	
CCTV BOX	350° Rotatable, 6-sided, back-opened
Strobe Light	Blue&White
Included Accessories	8-Port POE Switch
Optional Accessories	Cameras, NVR, 4G Router, Loud Speaker
General	
Working Temp	-20°C~55°C
Extended Dimensions	3225*3600*6962mm
Retracted Dimensions	1315*1385*2840mm
Gross Weight	990KG
QTY in 20' / 40'	8 units / 18 units

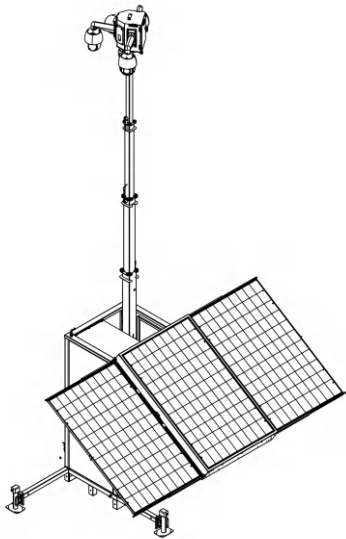

HiSKID-III™

MOBILE SOLAR CCTV TOWER

Rental. Sale. Own. Lease

- No Electricity
- No Network
- No Fuel
- No Problem!



HIGH-POWER SOLAR PANELS

Pull-out, Bifacial, Independent
Quick, Sturdy, Windproof
Rail Cover, Anti-jamming



FORKLIFT BASE

Large fork holes 4 adjustable jacks
4 reinforced lifting rings
Fork/lift for easy movement
Flexible adjustment suits varied terrains

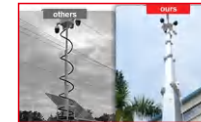

BUILT-IN WIRES

Internal Wiring Up to 9 Meters Height
Each Sections Hot-Dip Galvanized
Weatherproof Aging Prevention
Against Cutting or Vandalism
Extended Service Life

PRODUCT SKETCH

TECHNICAL DATA

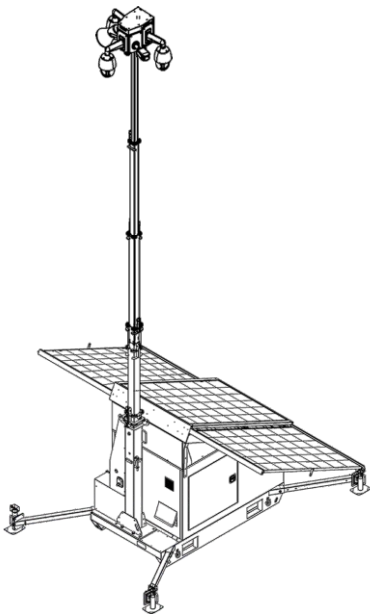

BASIC VERSION	BL3P-G7MHDS1B	BL3P-L7MHDS1B
Solar		
Solar Panel	3×450W, Bifacial	
Panel Tilting	25°-53° Manual	
MPPT Controller	60A-E With Remote Battery Monitoring	
Estimated Solar Charging Time	9 hours	
Back-up Generator		
Power Rating	3KW	
Fuel Tank	50L	
Auto-Start System	YES	
Battery		
Battery Type	GEL	LFP
Battery Capacity	14400WH	14336WH
Battery AC Charger	2.5kW AC110V/230V	
System Voltage	DC 24V	
Available Voltage	DC 24V,48V	
DC-to-AC Inverter	450W Rated	
Battery Backup Time	72 Hours Under 160W Load	
Telescopic Mast		
Mast Height	6.5M	
Lifting Winch	Manual	
Material	Hot-dip Galvanized Steel	
Feature	Build in Wiring	
CCTV		
CCTV BOX	350° Rotatable, 6-sided, back-opened	
Strobe Light	Blue&White	
Included accessories	8-Port POE Switch	
Optional accessories	Cameras, NVR, 4G Router, Loud Speaker	

PRO VERSION	BL3P-G9EHDS1P	BL3P-L9EHDS1P
Solar		
Solar Panel	3×450W, Bifacial	
Panel Tilting	25°-53° Manual	
MPPT Controller	45A-V With Remote Battery Monitoring	
Estimated Solar Charging Time	9 hours	
Back-up Generator		
Power Rating	3KW	
Fuel Tank	50L	
Auto-Start System	YES	
Battery		
Battery Type	GEL	LFP
Battery Capacity	14400WH	14336WH
Battery AC Charger	2.5kW AC110V/230V	
System Voltage	DC 24V	
Available Voltage	DC 24V,48V	
DC-to-AC Inverter	450W Rated	
Battery Backup Time	72 Hours Under 160W Load	
Telescopic Mast		
Mast Height	8.5M	
Lifting Winch	Electrical	
Material	Hot-dip Galvanized Steel	
Feature	Build in Wiring	
CCTV		
CCTV BOX	350° Rotatable, 6-sided, back-opened	
Strobe Light	Blue&White	
Included accessories	8-Port POE Switch	
Optional accessories	Cameras, NVR, 4G Router, Loud Speaker	

HiSTAR-III™

MOBILE SOLAR CCTV TOWER

Rental. Sale. Own. Lease

- No Electricity
- No Network
- No Fuel
- No Problem!



HIGH-POWER SOLAR PANELS

Pull-out, Bifacial, Independent
Quick, Sturdy, Windproof
Rail Cover, Anti-jamming



RUST RESISTANCE

Hot-dip galvanized telescopic mast and base
Zinc coating average thickness $\geq 100\mu\text{m}$
Outdoor powder-coated shell
Rust-proof in long-term humid environments

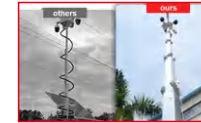

BUILT-IN WIRES

Internal Wiring Up to 9 Meters Height
Each Sections Hot-Dip Galvanized
Weatherproof Aging Prevention
Against Cutting or Vandalism
Extended Service Life

PRODUCT SKETCH

TECHNICAL DATA

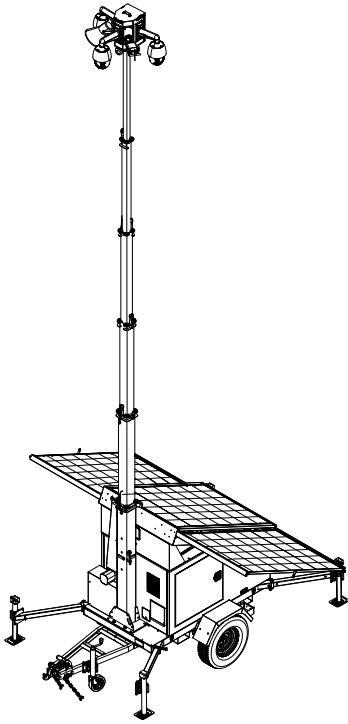

BASIC VERSION	BL3P-G7MHR51B	BL3P-L7MHR51B
Solar		
Solar Panel	3×450W, Bifacial	
Panel Tilting	25°-53° Manual	
MPPT Controller	60A-E With Remote Battery Monitoring	
Estimated Solar Charging Time	9 hours	
Back-up Generator		
Power Rating	3KW	
Fuel Tank	50L	
Auto-Start System	YES	
Battery		
Battery Type	GEL	LFP
Battery Capacity	14400WH	14336WH
Battery AC Charger	2.5kW AC110V/230V	
System Voltage	DC 24V	
Available Voltage	DC 24V,48V	
DC-to-AC Inverter	450W Rated	
Battery Backup Time	72 Hours Under 160W Load	
Telescopic Mast		
Mast Height	6.5M	
Lifting Winch	Manual	
Material	Hot-dip Galvanized Steel	
Feature	Build in Wiring	
CCTV		
CCTV BOX	350° Rotatable, 6-sided, back-opened	
Strobe Light	Blue&White	
Included accessories	8-Port POE Switch	
Optional accessories	Cameras, NVR, 4G Router, Loud Speaker	

PRO VERSION	BL3P-G9EHR51P	BL3P-L9EHR51P
Solar		
Solar Panel	3×450W, Bifacial	
Panel Tilting	25°-53° Manual	
MPPT Controller	45A-V With Remote Battery Monitoring	
Estimated Solar Charging Time	9 hours	
Back-up Generator		
Power Rating	3KW	
Fuel Tank	50L	
Auto-Start System	YES	
Battery		
Battery Type	GEL	LFP
Battery Capacity	14400WH	14336WH
Battery AC Charger	2.5kW AC110V/230V	
System Voltage	DC 24V	
Available Voltage	DC 24V,48V	
DC-to-AC Inverter	450W Rated	
Battery Backup Time	72 Hours Under 160W Load	
Telescopic Mast		
Mast Height	8.5M	
Lifting Winch	Electrical	
Material	Hot-dip Galvanized Steel	
Feature	Build in Wiring	
CCTV		
CCTV BOX	350° Rotatable, 6-sided, back-opened	
Strobe Light	Blue&White	
Included accessories	8-Port POE Switch	
Optional accessories	Cameras, NVR, 4G Router, Loud Speaker	

HiSTAR-V™

MOBILE SOLAR CCTV TOWER

Rental. Sale. Own. Lease

- No Electricity
- No Network
- No Fuel
- No Problem!



DIESEL GENERATOR

- Auto-charges when battery is low
- Large fuel tank
- Non-stop runtime on cloudy days/winter



RUST RESISTANCE

- Hot-dip galvanized telescopic mast base and outriggers
- Zinc coating average thickness $\geq 100\mu\text{m}$
- Outdoor powder-coated shell
- Rust-proof in long-term humid environments

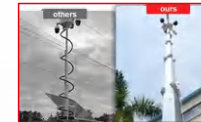

BUILT-IN WIRES

- Internal Wiring Up to 9 Meters Height
- Each Sections Hot-Dip Galvanized
- Weatherproof Aging Prevention
- Against Cutting or Vandalism
- Extended Service Life

PRODUCT SKETCH

TECHNICAL DATA

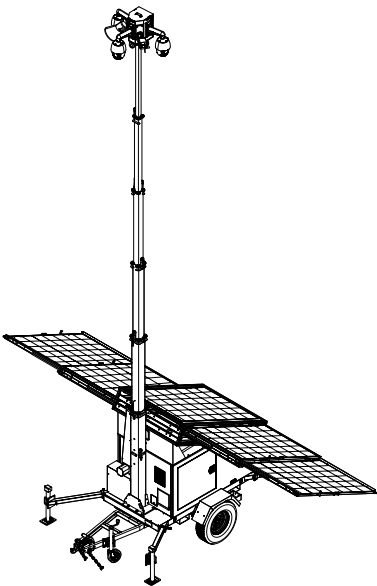

BASIC VERSION	BL5P-G7MHR51B	BL5P-L7MHR51B
Solar		
Solar Panel	5×450W, Bifacial	
Panel Tilting	25°-53° Electrical	
MPPT Controller	80A-E With Remote Battery Monitoring	
Estimated Solar Charging Time	7.7 hours	
Back-up Generator		
Power rating	3KW	
Fuel Tank	50L	
Auto-start system	YES	
Battery		
Battery Type	GEL	LFP
Battery Capacity	19200WH	20480WH
Battery AC Charger	2.5kW AC110V/230V	
System Voltage	DC 48V	
Available Voltage	DC 24V,48V	
DC-to-AC Inverter	450W Rated	
Battery Backup Time	72 Hours Under 213W Load	
Telescopic Mast		
Mast Height	6.5M	
Lifting Winch	Manual	
Material	Hot-dip Galvanized Steel	
Feature	Build in Wiring	
CCTV		
CCTV BOX	350° Rotatable, 6-sided, back-opened	
Strobe Light	Blue&White	
Included accessories	8-Port POE Switch	
Optional accessories	Cameras, NVR, 4G Router, Loud Speaker	

PRO VERSION	BL5P-G9EHR51P	BL5P-L9MHR51P
Solar		
Solar Panel	5×450W, Bifacial	
Panel Tilting	25°-53° Electrical	
MPPT Controller	90A-V With Remote Battery Monitoring	
Estimated Solar Charging Time	7.7 hours	
Back-up Generator		
Power Rating	3KW	
Fuel Tank	50L	
Auto-Start System	YES	
Battery		
Battery Type	GEL	LFP
Battery Capacity	19200WH	20480WH
Battery AC Charger	2.5kW AC110V/230V	
System Voltage	DC 48V	
Available Voltage	DC 24V,48V	
DC-to-AC Inverter	450W Rated	
Battery Backup Time	72 Hours Under 213W Load	
Telescopic Mast		
Mast Height	8.5M	
Lifting Winch	Electrical	
Material	Hot-dip Galvanized Steel	
Feature	Build in Wiring	
CCTV		
CCTV BOX	350° Rotatable, 6-sided, back-opened	
Strobe Light	Blue&White	
Included accessories	8-Port POE Switch	
Optional accessories	Cameras, NVR, 4G Router, Loud Speaker	

HiTOP™

SOLAR CCTV KIT

Rental. Sale. Own. Lease



HiPT™

TELESCOPIC MAST WITH BASE

Rental. Sale. Own. Lease



PRODUCT SKETCH

TECHNICAL DATA

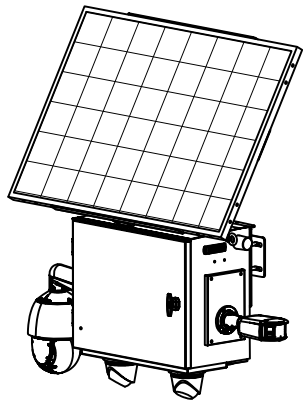

HiTOP	BL1P-L0NHTPS0N
Solar	
Solar Panel	200W
Panel Adjustment	90° rotatable and tiltable
Solar Controller	15A-E
Estimated Solar Charging Time	5.4 hours
Battery	
Battery Type	LFP
Battery Capacity	1280WH
Power Output	DC12V/24V/48V
Battery Backup Time	72 Hours Under 14W
Mounting&Dimensions	
Pole Mounting	Pole diameter ≤φ88-φ148
Wall Mounting	M12 chemical/expansion bolts needed
HiPT Mounting	Direct Mounting
General	
Working Temp	-20°C~55°C
Box Zize	620*500*330mm
panel Zize	1170*780*30mm
Gross Weight	90KG
QTY in 20' / 40'	30 units / 60 units

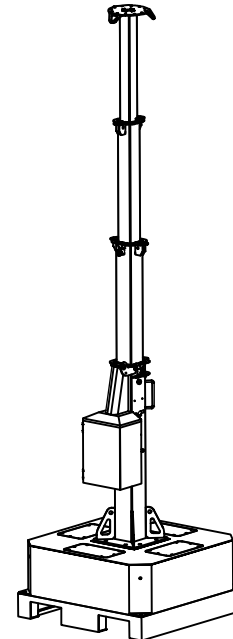

HiPT	BL0P-N4MHTNNN
Payload	50KG
Height	3.5M
Material	Q235 Steel, Each Section Hot-Dip Galvanized
Mast Lifting	Manual Winch
Base	Hollow, Metal, Hot-Dip Galvanized
Lifting Ring	4 ×
Forklift Holes	2 ×
Dimension(Extended)	1100*1100*3889mm
Dimension(Retracted)	1100*1100*1825mm
Weight	231KG
QTY in 20' / 40' Container	27 units / 56 units

SOLUTIONS

MOBILE SOLAR CCTV TOWER

Rental. Sale. Own. Lease

BIGLUX develops and implements specific & innovative mobile solar tower and mobile solar generator solutions for different commercial and industrial applications. By adopting the latest renewable energy technologies, BIGLUX integrated solar and battery system to develop and implement the most energy saving renewable mobile solar power systems to work as solar surveillance tower, solar lighting tower, solar generator, solar telecom tower solutions for multiple applications:

- Outdoor Parking Lots
- Traffic Monitoring
- Construction Sites
- Emergency Rescue
- Public Security
- Sports and Events

- Forest Fire Prevention
- Military Bases
- Mining and Oil
- Refuse Disposal Plants
- Logistics Centers
- Defense Frontiers

- Airports
- Camping
- Agriculture
- Telecom
- Industry
- Data Centers



INNOVATION DRIVEN QUALITY ORIENTED

BIGLUX is a quality-oriented and innovation-driven company. With a strong focus on independent research and development, we have consistently achieved breakthroughs in leading technologies. Our commitment to excellence enables us to meet the diverse and personalized needs of customers across various industries. Whether it's through pioneering advancements or tailored solutions, BIGLUX is dedicated to delivering superior products and services that cater to the unique requirements of each client.

10+ Years Experience

Our rich experience and past lessons in the industry can help customers avoid detours and get better product and service experience.

20+ Certificates

We have obtained most of the professional certificates in the industry and insist on international standards of production.

100+ Repeat Order Customers

Thanks to our customers trust and support, the continuous orders from old customers are an important cornerstone of BIGLUX stable development.





Strict Quality Control

- 3-Step Quality Check Process
- Raw Material QC
- In-Process Semi-finished QC
- Pre-shipment Finished Product QC



2 Years Warranty

We guarantee 2 - year warranty for the whole system, non - vandalism quality problems get timely repair/replacement, life - long repairing responsibility.



Professional Team

8 Departments in BIGLUX.
From Concept Design to Manufacturing,
Delivering One - Stop Closed - Loop Services.



Faster Deliver

Samples: 5~7 working days.
Bulk Orders: 25~45 working days.

5A We Have

- A strong expertise in SOLAR TOWER latest technologies.
- A broad experience in SOLAR TOWER applications.
- An insatiable thirst for smart intelligent controlled SOLAR TOWER system.
- A background of over 10 years' experience in MOBILE SOLAR industry.
- A great heart of contribution to the most energy saving and environment friendly world.



For The Society

We provide long-term energy-saving solutions: save energy, save the world. Mobile solar power with lighting, telecom & CCTV helps communities stay connected and extends work hours for construction, mining and oil sites etc.



For The Industry

We are quality-focused and innovation-led. At BIGLUX, innovation drives mobile solar solutions, fuels product breakthroughs, and leads the industry.



For Our Customer

We strive to deliver standout solutions. Leveraging China's raw materials, innovative tech, workforce, and sub-assembly capabilities, BIGLUX offers highly competitive product across the world.



For Our Staff

We aspire to build a TEAM where every member thrives in work-life balance, and each contribution fuels collective success.



BIGLUX INNOVATION LTD

www.bigluxsolar.com www.bigluxled.com

WhatsApp: +86 188 1878 5601

Email: info@bigluxsolar.com

Add: Building 6, No. 34 Guanghui Road, Longteng Community, Shiyan Street, Bao'an District, Shenzhen, China
